

BOREQUIP FLEXIBLE RISING MAIN **HOSE**

BASIC SPECIFICATION & INSTALLATION MANUAL





Contents

- | | | |
|----|--------------------|---|
| 1. | Why Borequip? | 2 |
| 2. | Specifications | 3 |
| 3. | Couplings | 4 |
| 4. | Friction Loss | 5 |
| 5. | Installation guide | 6 |

This document serves as a **basic** specification and installation manual to assist Borequip clients. This manual is to be used in conjunction with professional assistance and is only applicable with Borequip hose and its related products.



Why Borequip?



Borequip flexible rising main (FRM) hose is installed in many submersible pump applications in the mining, agriculture, environmental, municipal, industrial and solar-power industries.

Far more adaptable than other systems and much lighter than steel, FRM hose is ideal for use in confined spaces where headroom is an issue.

Borequip FRM hose has been specifically designed to replace rigid riser pipes such as steel which is subject to rust and encrustations. This internal scaling reduces flow rates and pump efficiency. Other risers such as PVC and polypipe can be brittle or bend. They are also generally heavier and hard to handle.



**3 year
warranty**

Advantages:

- Safe
- Easy to store & transport
- Efficient (shortened installation time)
- Long Lasting
- Easy to install and retrieve
- Hose Size 32mm - 202mm
- Pressure rating from 14 bar - 22 bar
- Couplings & joiners available for all sizes

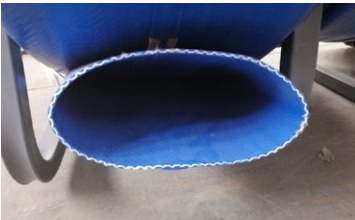



Specifications

Hose Specifications

Size	1¼"	1½"	2"	2½"	3"	4"	5"	6"	8"
Inside Dia.	32mm	40mm	50mm	65mm	76mm	102mm	127mm	152mm	202mm
Wall thickness (mm)	2 - 3	2.3 - 3.5	2 - 2.7	2.6 - 3.2	2.6 - 3.1	3.3 - 4	3.2 - 6.3	4 - 5.5	3.8 - 4.4
Weight (kg/m)	0.34	0.48	0.62	0.82	0.98	1.5	1.83	2.55	3.46
Operating Pressure	22bar	22bar	22bar	20bar	20bar	20bar	20bar	20bar	14bar
Bursting Pressure	65bar	65bar	65bar	60bar	60bar	60bar	60bar	60bar	42bar
Tensile Strength (kg)	2 100	3 000	4 000	6 000	8 000	15 000	18 000	24 000	30 000
Max. Loading (kg)	750	1 080	1 600	2 400	3 600	5 000	6 000	8 000	10 000
Minimum well diameter (mm)	76	102	102	152	152	203	255	305	406
Cover & lining materials (Polyurethane)	PU	PU	PU	PU	PU	PU	PU	PU	PU



Couplings

Typical coupling details *drawings are not to scale

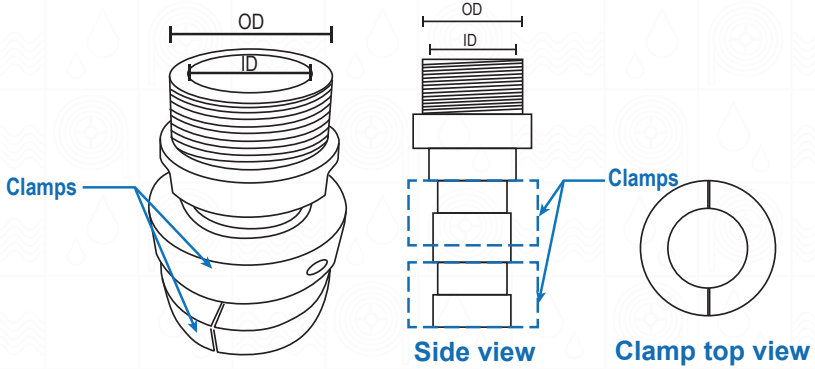

**Stainless steel couplings available
in sizes from 1¼" to 8".**





Friction Loss

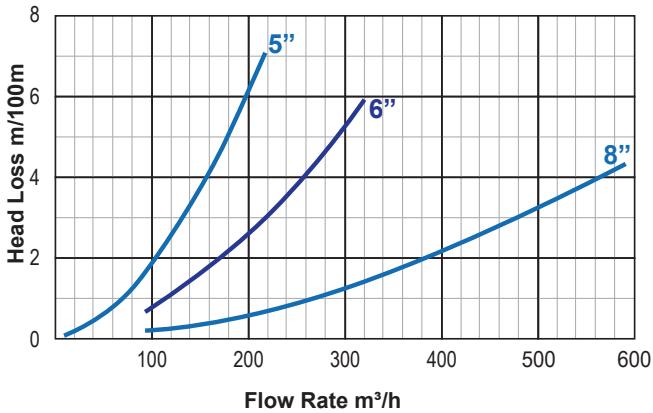
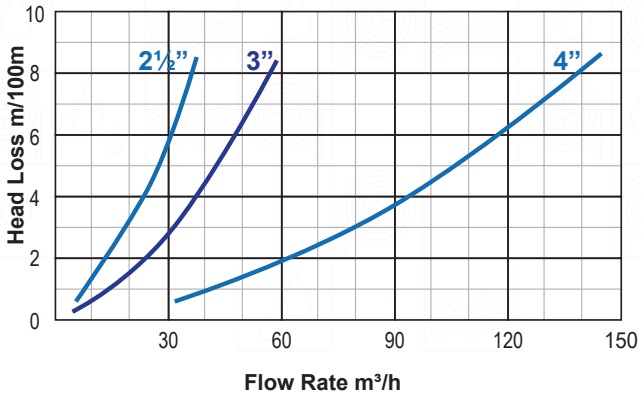
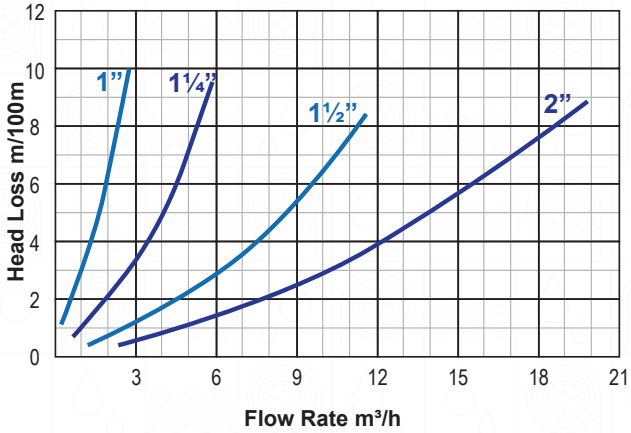



Installation guide

1. Connect hose to pump

Screw the coupling into the check-valve (non-return valve) located at the top of the pump.

Push the Boreline riser over the coupling body making sure the riser end is flush with the shoulder at the threaded end of the coupling. Do not use any kind of lubricant.

Fit the first ring with the three segments, over the rib closest to the threaded end of the coupling body. Tighten all screws evenly, ensuring the gaps between the segments are even. When fully tightened the gaps between these segments should be 1-2mm. If a Torque wrench is not available we recommend hand tightening with long series allen keys. Do not overtighten or use extension bars.

Fit the second ring over the second rib positioning the gaps half way between the gaps of the first ring and tighten as above.

Step 1



Step 2



Step 3



Step 4



Step 5



Step 6





Installation guide

2. Attach power cable using Borequip cable straps



IMPORTANT - The power cable should only be connected to the pump motor by a qualified electrician.





Installation guide

3. Lower into borehole

Vehicle

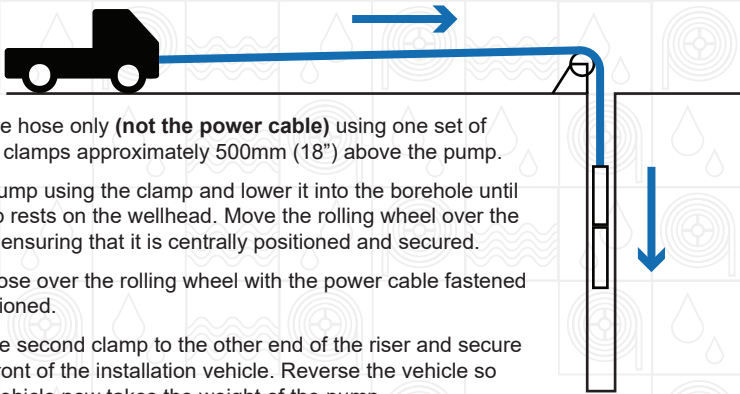

Clamp the hose only (**not the power cable**) using one set of Borequip clamps approximately 500mm (18") above the pump.

Lift the pump using the clamp and lower it into the borehole until the clamp rests on the wellhead. Move the rolling wheel over the borehole ensuring that it is centrally positioned and secured.

Lift the hose over the rolling wheel with the power cable fastened and positioned.

Attach the second clamp to the other end of the riser and secure it to the front of the installation vehicle. Reverse the vehicle so that the vehicle now takes the weight of the pump.

Remove the first clamp. (The full load will now be taken by the vehicle and rolling wheel.)

Drive the vehicle slowly forward allowing the pump and riser to be lowered into the borehole.

Joiners, couplings and clamps must not pass over the rolling wheel.

When the vehicle is close to the rolling wheel, clamp the riser above the wellhead. Lower the riser slightly so that this clamp now rests on the wellhead and remove the other clamp from the vehicle.



Clamp



Rolling wheel



Installation guide

3. Lower into borehole

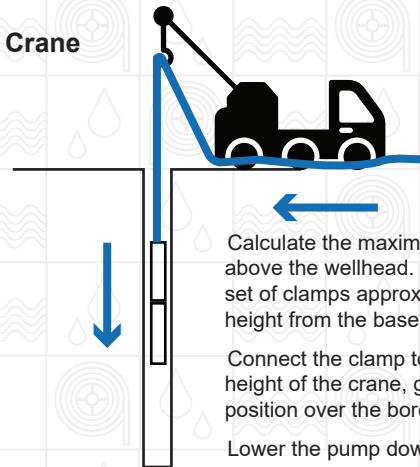

Crane

Calculate the maximum height that the eye of the crane can achieve above the wellhead. Clamp the hose only (not the power cable) using one set of clamps approximately 1000mm (3 ft) less than the crane maximum height from the base of the pump.

Connect the clamp to the crane hook and lift the hose to the maximum height of the crane, guiding the pump as it is moved into the vertical position over the borehole.

Lower the pump down the borehole until the clamp rests on the wellhead.

Secure the second clamp at the maximum lifting height to the Boreline riser less 1000mm (3 ft), raise this clamp to take up the slack and release the first clamp off the well head. Once the top clamp has taken all the weight remove the lower clamp. Repeat this operation to continue lowering the pump down the borehole.

On the last lift raise the head works until the weight of the whole assembly is taken, remove the clamp and lower the assembly onto the borehole. The hose must not be dragged over the edge of the casing as this will cause damage.

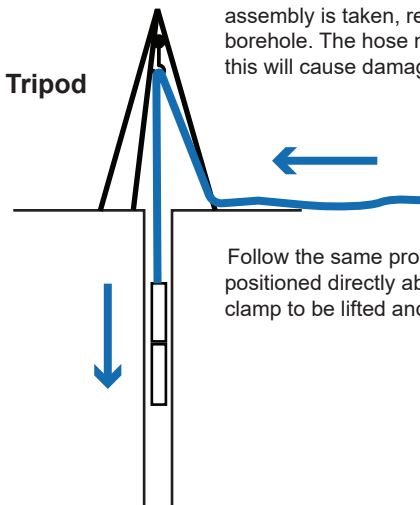

Tripod

Follow the same procedure as with the vehicle. The tripod should be positioned directly above the borehole high enough to allow the pump and clamp to be lifted and then lowered over the borehole.



BOREQUIP



 facebook.com/Borequip

HEAD OFFICE (CT):
+27 (021) 949 0902
sales@borequip.co.za
10 Kouga Street
Stikland
Bellville

VANSAN PE:
+27 (041) 450 7803
riette@vansan.co.za
134B Paterson Road
Sydenham
Port Elizabeth

VANSAN PTA:
+27 (012) 819-1196
sales@vansan.co.za
10 Escalonia Road
Montana Park x91
Pretoria